

SPECIFICATION



ER32L065 3.6V



Electrical characteristics

(Typical values relative to cells stored for one year at +30 °C max)

○ Nominal capacity	1000mAh
Discharged capacity at 1mA, +25 °C, 2.0V cut off	
○ Open circuit voltage	3.66V
○ Max. recommended continuous current	10mA
Discharged to 2.0V at +25 °C permitting 50% of the nominal capacity to be achieved	
○ Max. Pulse capability	20mA
20mA, 0.1 second pulses every 2 minutes, drained with 50%, 1mA at 25 °C from undischarged cells with 20µA base current, yield voltage readings above 2.7V, the value may vary according to the pulse characteristics, the temperature and the cell's previous history	
○ Operating temperature rang	-55 °C ~ +125 °C

STORAGE:

Stored in clean, dry and cool circumstances (the temperature should be 20 degrees or lower, less than 30 degrees)

WARNING:

Don't charge, crush, disassemble, expose contents to water, heat above 125 °C or may lead to explosion, burn or poison goods leakage. Discarded battery should be buried deeply to the ground.

Key features

- High and stable operating voltage
- Long shelf life
- Annual self-discharge rate lower than 1% at +25 °C
- Long operating life
- High energy density (700wh/kg)
- Wide operating temperature rang
- Stainless steel can and cover
- Perfect sealing behaviour below 125 °C
- Non-flammable electrolyte
- Compliant with IEC 86-4 safety standard
- Non-restricted for transport

 UL Component Recognition
File Number MH46165

Main applications

- TPMS
- Alarms or security equipment
- Memory backup
- GPS tracking
- Car electronics
- Professional electronic equipment
- Real time clock

.....

ER32L065

1000mAh

Discharge characteristics at 25°C

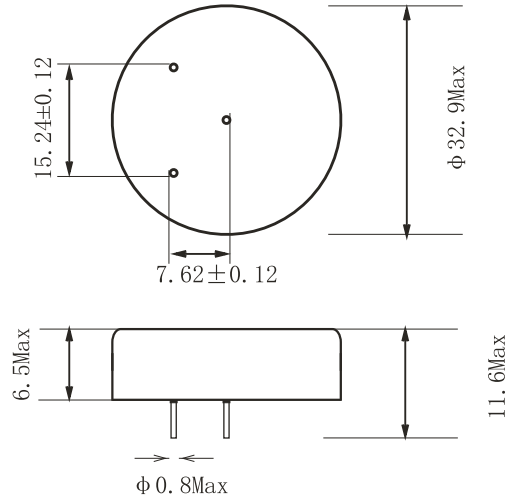
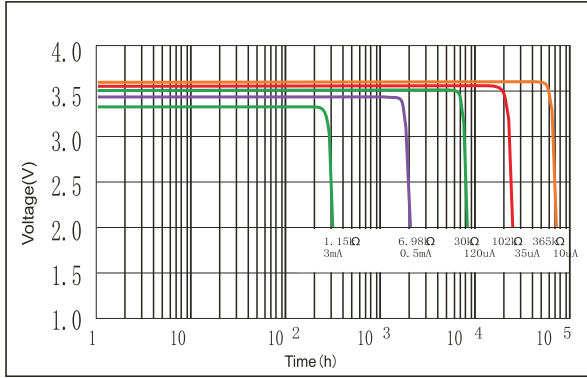

Dimensions in mm
Weight: 17g

Voltage vs Current curve

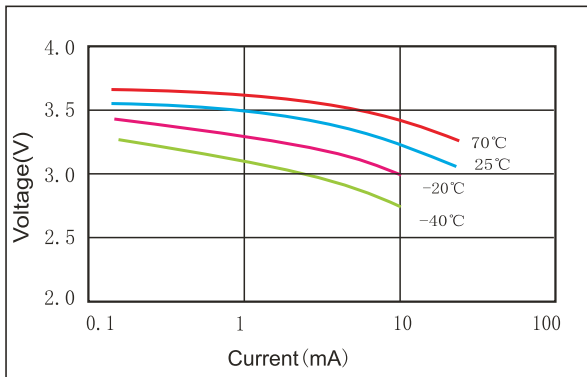

Available Terminations	
-/P*	Axial pin
-/T /PT2*	Radial Pin
-/PT /TP*	Polarized Tab
(*) : Reference to Standard Terminals for Single Cells	

Capacity vs Current curve

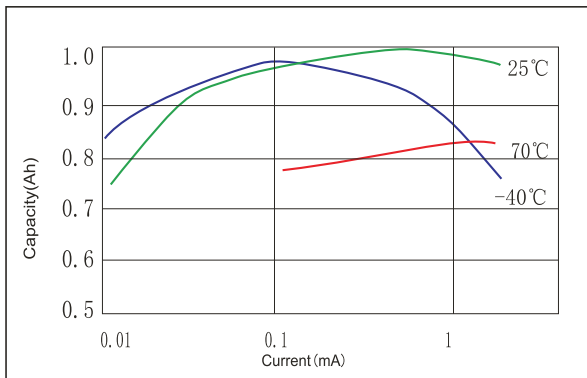

Discharge characteristics after storage

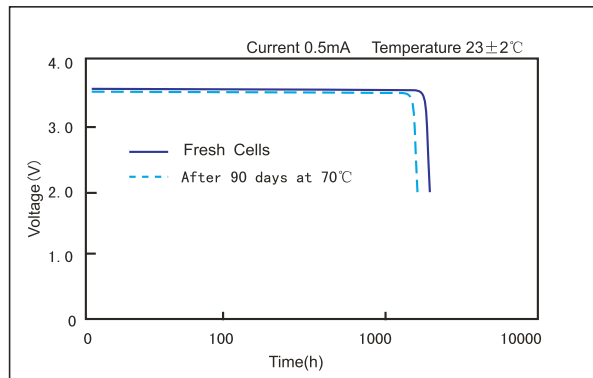

Data in this page is subject to change without notice and becomes contractual only after written confirmation by Fute.