



SPEC. NO.	KL36H91x.XXX/KL36HS91x.XXX Series	ISSUE DATE	2015-7-20		
DESCRIPTION	Lithium Ion Battery For E-bike	EDITION	B	PAGE	1/10

1. Applicability

The specification is applicable to Mondia Lithium Ion Rechargeable batteries

1.1 Product code

KLxxHyyz.nnn	E-bike Battery (without Gas Gauge) 4P10S
KLxxHSyyz.nnn	E-bike Battery (with Gas Gauge) 4P10S
KL: E-bike/Power pack serial code xx: Voltage level H: This product maximum continue discharge current up to 15A S: This product Build in Gas Gauge function yy: Serial Number z: Color nnn: Cell Type	

2. Ratings

2.1 Cell

Item	KL36H91x.082 KL36HS91x.082	KL36H91x.809 KL36HS91x.809	
Type of Cell	Sealed Lithium-ion cylindrical Rechargeable battery		
Cell Size	18650		
Cell Model	PSI UR18650AA	PSI NCR18650PD	
Cell UL Number	MH12383	MH12210	
Cell Typical capacity	2250mAh	2880mAh	
Cell Minimum capacity	2150mAh	2730mAh	
Continuous Discharge current	5000mA	10,000mA	
Item			
Type of Cell			
Cell Size			
Cell Model			
Cell UL Number			
Cell Typical capacity			
Cell Minimum capacity			
Continuous Discharge current			



SPEC. NO.	KL36H91x.XXX/KL36HS91x.XXX Series	ISSUE DATE	2015-7-20		
DESCRIPTION	Lithium Ion Battery For E-bike	EDITION	B	PAGE	2/10

2.2 Pack

2.2.1 Rated voltage & Maximum Charge Voltage

Series	Rated voltage	Maximum Voltage	Maximum Charge Voltage
10S	36V	42V	42.5V

2.2.2 Internal impedance: Less than 200mohm

2.2.3 Capacity

Model no.	Typical Capacity	Minimum Capacity
KL36H91x.082 KL36HS91x.082	9Ah	8.6Ah
KL36H91x.809 KL36HS91x.809	11.52Ah	10.92Ah

2.4 charge Current

Model no.	Standard charge current	maximum charge current
KL36H91x.082 KL36HSP91x.082	1350mA	2350mA
KL36H91x.809 KL36HS91x.809	1350mA	2350mA

2.2.5 Standard and Maximum discharge current

Model no.	Standard discharge current	Max. continue discharge current	Max. Pulse discharge current	
			10min.	5S
KL36H91x.082 KL36HSP91x.082	1.72A	15A	18A	35A
KL36H91x.809	2.16A	15A	18A	35A



SPEC. NO.	KL36H91x.XXX/KL36HS91x.XXX Series	ISSUE DATE	2015-7-20		
DESCRIPTION	Lithium Ion Battery For E-bike	EDITION	B	PAGE	3/10

KL36HS91x.809					

2.2.6 Safety Device and Function Requirement

Item	Spec.
Overcharge Protection	4.30±0.025V/cell
2nd-Level Overcharge protection	4.45±0.025V/cell
Over discharge Protection	2.50±0.025V/cell
Over current protection	40A±5A
Short Current Protection	OUT+/OUT- Short Current
Temperature protection	>70°C: Can not Charge & Discharge <0°C or >50°C: Can not Charge
Cell balancing	>4.18V Balancing Action
Reverse charge Protection	Can not charge
Build-in Gas Gauge	Using HDQ communication standard

2.2.7 Operating temperature: 0 - 45°C (standard charge)

10 - 45°C (quick charge)

-20 - 60°C (standard discharge)

2.2.8 Storage temperature: -20 - 50°C (1 week)

-20- 45°C (1 month)

-20 - 40°C (6 months)

-20 - 35°C (1 year)

2.3 Test conditions

Unless otherwise specified, all tests should be conducted within one Month of delivery under the following conditions:

SPEC. NO.	KL36H91x.XXX/KL36HS91x.XXX Series	ISSUE DATE	2015-7-20		
DESCRIPTION	Lithium Ion Battery For E-bike	EDITION	B	PAGE	4/10

Ambient temperature: 20 +/- 5°C.

Relative humidity: 65 +/- 20%.

3. Charge and discharge Port Pin definition

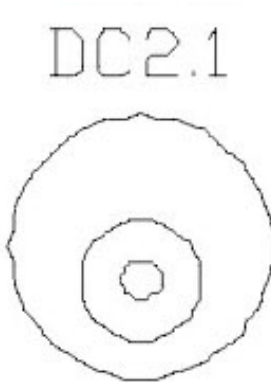
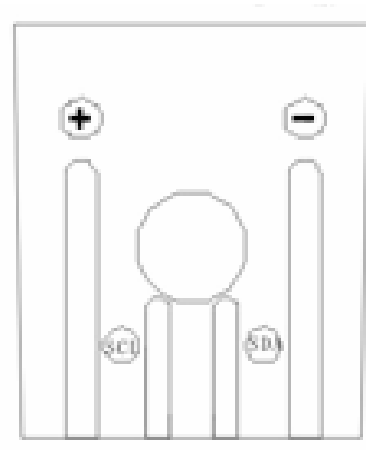
Charge Port	Discharge port																						
																							
<table border="1"> <thead> <tr> <th>Pin No.</th> <th>Polarity</th> </tr> </thead> <tbody> <tr> <td>CENTER</td> <td>Positive (+)</td> </tr> <tr> <td>OUTER</td> <td>Negative (-)</td> </tr> </tbody> </table>	Pin No.	Polarity	CENTER	Positive (+)	OUTER	Negative (-)	<table border="1"> <thead> <tr> <th>Pin No.</th> <th>KL36HS91x.XXX</th> <th>KL36H91x.XXX</th> </tr> </thead> <tbody> <tr> <td>(-)</td> <td>Negative(P-)</td> <td>Negative(P-)</td> </tr> <tr> <td>(SDA)</td> <td>HDQ</td> <td>NC</td> </tr> <tr> <td>(SCL)</td> <td>GND(communication)</td> <td>NC</td> </tr> <tr> <td>(+)</td> <td>Positive (P+)</td> <td>Positive(P+)</td> </tr> </tbody> </table>		Pin No.	KL36HS91x.XXX	KL36H91x.XXX	(-)	Negative(P-)	Negative(P-)	(SDA)	HDQ	NC	(SCL)	GND(communication)	NC	(+)	Positive (P+)	Positive(P+)
Pin No.	Polarity																						
CENTER	Positive (+)																						
OUTER	Negative (-)																						
Pin No.	KL36HS91x.XXX	KL36H91x.XXX																					
(-)	Negative(P-)	Negative(P-)																					
(SDA)	HDQ	NC																					
(SCL)	GND(communication)	NC																					
(+)	Positive (P+)	Positive(P+)																					

SPEC. NO.	KL36H91x.XXX/KL36HS91x.XXX Series	ISSUE DATE	2015-7-20		
DESCRIPTION	Lithium Ion Battery For E-bike	EDITION	B	PAGE	5/10

4. Dimensions:

Material of Case	Plastic (ABS+PC UL V-0VA)	Battery weight	Approx. 2331g
Color	/	Switch Control	Rocker switch

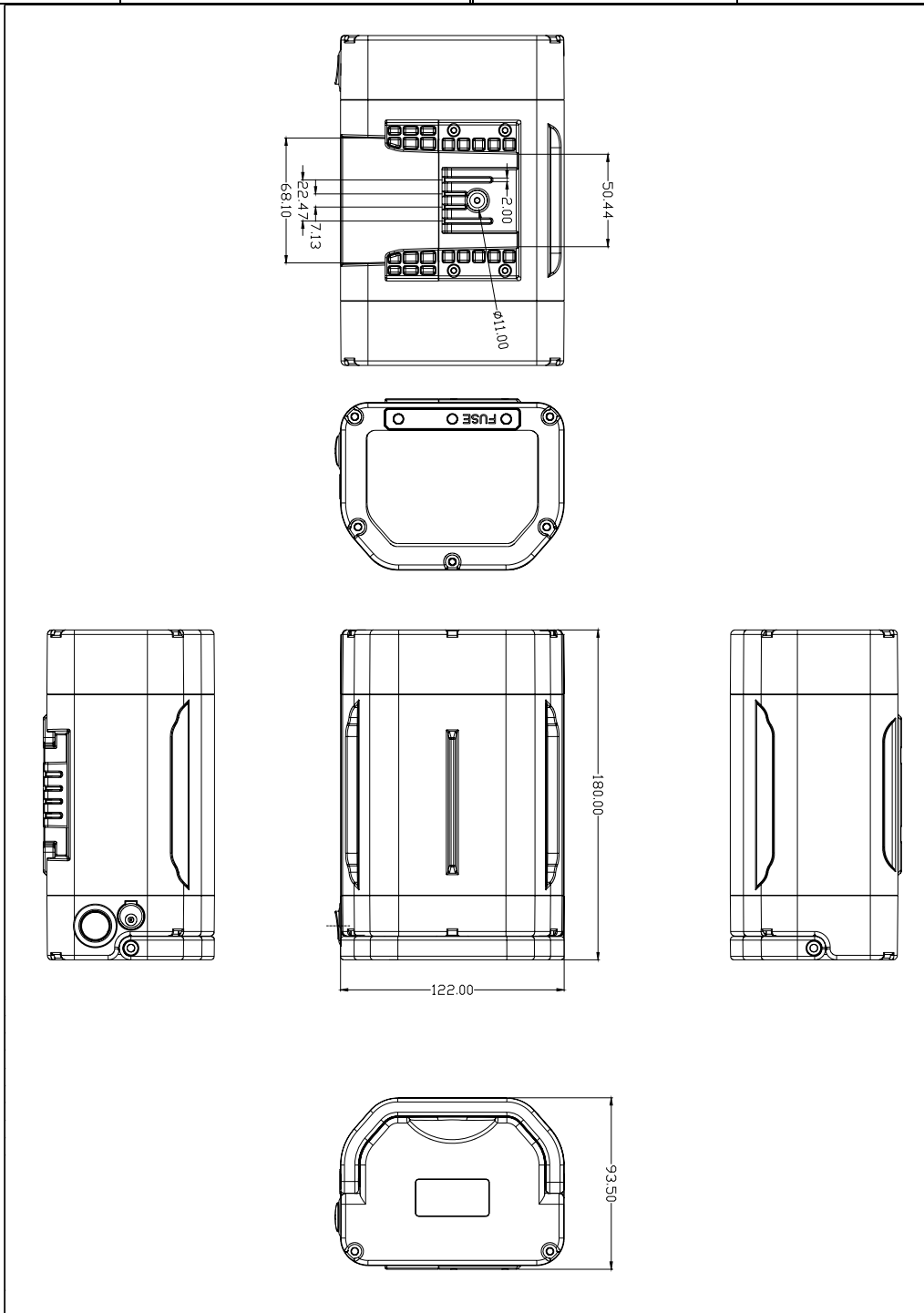

SPEC. NO.	KL36H91x.XXX/KL36HS91x.XXX Series	ISSUE DATE	2015-7-20		
DESCRIPTION	Lithium Ion Battery For E-bike	EDITION	B	PAGE	6/10

5. An Circuit diagram for connect battery and HDQ communication module

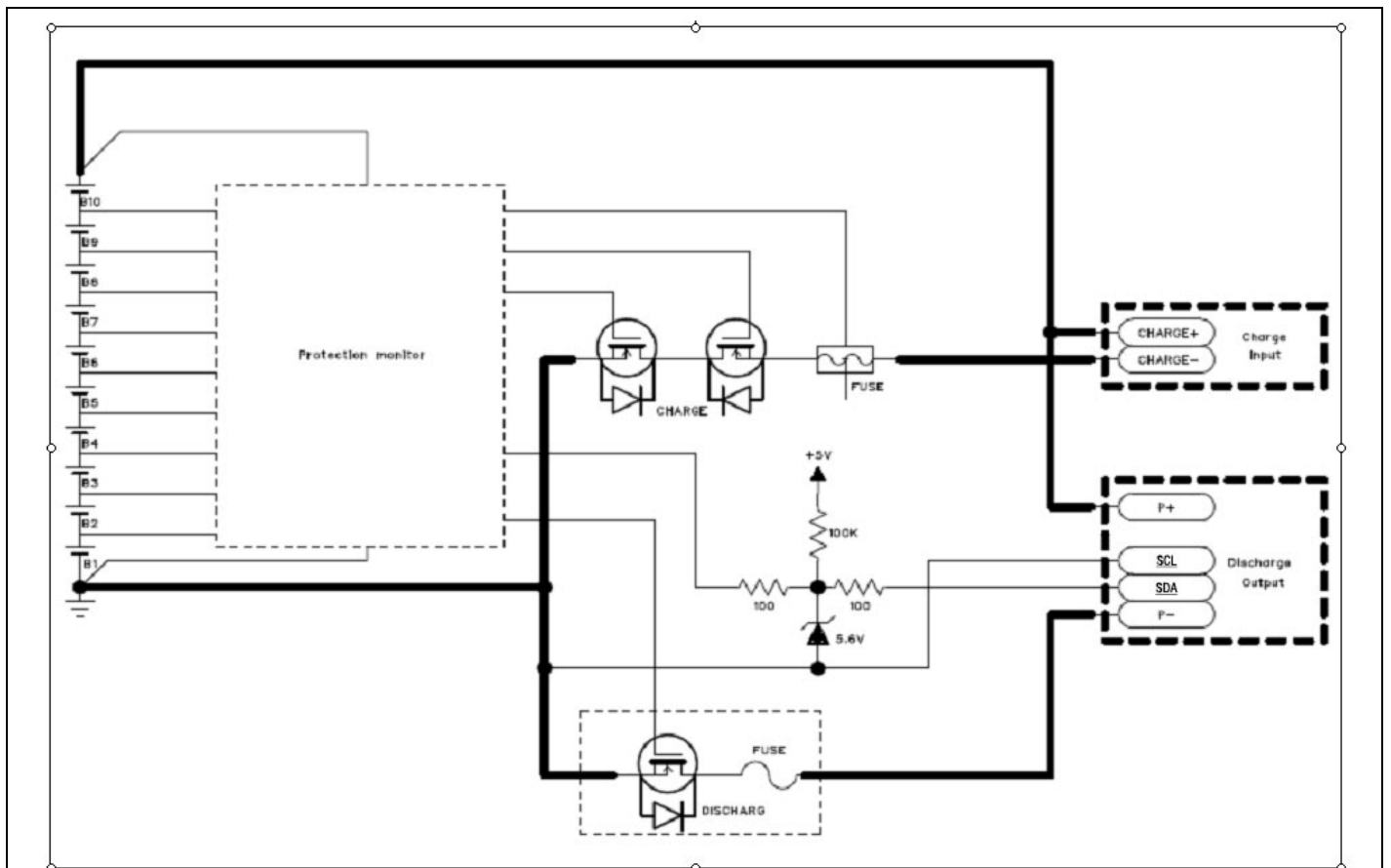

Note:

1. Battery Communication is single wire HDQ with reference to GND ONLY. Do not directly or indirectly connect GND and P-.
2. Our smart battery designed for HDQ communication standard and only connect with the specify product. If customer use other equipment to communication, Please note the following information.

Problems related to incorrect reference connections:

SPEC. NO.	KL36H91x.XXX/KL36HS91x.XXX Series	ISSUE DATE	2015-7-20		
DESCRIPTION	Lithium Ion Battery For E-bike	EDITION	B	PAGE	7/10

Case	use P-instead of GND					Connect P-with GND			
Load	No load		Loading			No load	Loading		
Protection Status	NORMAL	/	Over Discharge	/	NORMAL	/	NORMAL	/	Over Discharge
Switch	ON	OFF	ON	OFF	ON	/	ON	Off	/
Result	Can communicate with Battery	No communication with Battery	Permanent damage on 100ohm Resistor		Unreliable communication with Battery	Battery can not turn off	Unreliable communication with Battery	Permanent damage on GND wire	

6. Performance (Note 1)

Item	Criteria	Test conditions
Capacity	Above Minimum Capacity	Standard charge and standard discharge
Internal impedance	Refer to Model detail	Measure AC impedance at 1kHz
Cycle life (Note 2)	Above 0.7* Typical Capacity	300 cycles charging/discharging is repeated in the below condition. <ul style="list-style-type: none"> ● Charging: Standard Charge ● Rest time: 20min ● Discharging: Standard Discharge ● Temperature: 25±2°C
Leakage resistance	No leakage	Visually inspect battery pack after standard charge and storage at 25°C for 14 days.
Drop test	No fire, no explosion, no leakage (max. weight loss 0.1%)	Drop battery pack after standard charged onto a bakelite floor from a height of 50 cm for 6 times.
Vibration test	No fire, no explosion, no leakage (max. weight loss 0.1%)	The battery pack is vibrated in triaxial direction with 4 mm amplitude of frequency 30 Hz for 1 minute in each direction.
Short circuit test	No fire, no explosion, cell temperature shall not exceed 150°C	External short circuit



SPEC. NO.	KL36H91x.XXX/KL36HS91x.XXX Series	ISSUE DATE	2015-7-20		
DESCRIPTION	Lithium Ion Battery For E-bike	EDITION	B	PAGE	8/10

Appearance	No crack, no leakage, no deformation	Visual inspection
------------	--	-------------------

Note:

1. Unless otherwise specified, all tests should be conducted within one month of delivery under the following conditions :
Ambient temperature :20 +/- 5°C
Relative humidity:65 +/- 20%.
2. Data provided under "Cycle Life" in this document is our best estimate based on the technical data supplied by battery cell manufacturer in the Product Specification Form.

7. Warranty

One year limited warranty for bike and bike parts against workmanship and material defects outside wear and tear due to normal usage.

8. Charge state of cell before shipment

Charge from 50% to 90% according to delivery condition.

9. Safety precaution

Please follow the safety precaution carefully as improper handling of lithium ion batteries may result in injury or damage from electrolyte leakage, heating ignition or explosion. To ensure safety, consult with Master Instruments Pty Ltd regarding the charge and discharge specifications, equipment structure, warning labels and other important details when designing equipment to use with rechargeable lithium ion batteries supplied by Master Instruments Pty Ltd.

- Never charge the battery above 4.25V per cell.
- Never reverse charge the battery.
- Never heat or incinerate the battery.
- Never pierce, crush or cause mechanical damage to the battery.
- Never charge a battery at high temperature condition, such as at or near a fire.
- Never short circuit the battery.
- Never discharge a battery to below 2.75V per cell.
- Never allow the battery to get wet or be immersed in water.
- For long period of storage, temperature should be below 45°C
- After long period of storage, battery may required some cycling to recover capacity.

SPEC. NO.	KL36H91x.XXX/KL36HS91x.XXX Series	ISSUE DATE	2015-7-20		
DESCRIPTION	Lithium Ion Battery For E-bike	EDITION	B	PAGE	9/10

10. Packaging specification:

Component display

Battery

Top cover

Bottom cover

Put battery in the box

Insert top cover

1

2

3

4

Packing dimension
Dimension:
389*260*130mm
Weight: 9.0kg

Item	Materials	Description
1	Battery	48V 14.5Ah
2	Sparger cover	J757245073mm
3	Sparger base	J2571645750mm
4	Box	389*260*130mm
5	Label	28*60*110mm

